

ALL DAY FENCING Heavy Duty Sliding gate opener



FEATURES :

Up to 400Kg gate Heavy Duty DC Motor capable of handling heavy gates.

Build-in Backup Battery for emergency power failure operation.
Security Remote Controls Self-learning type with rolling code safety and 4 buttons for the convenience of operating any three different roller doors or garage doors (matching receivers available to make use of the remaining buttons).

Pedestrian entry Function. The gate can be opened fully or 1/2 way allowing pedestrians to come in.

Slow Down Speed The gate slows down automatically at the end of closure and opening for smooth and safe operation.

Learning Cycle System The unit's computerized control panel learns the operating time-cycle of the gate and sets itself automatically to slow down at the end of closure and opening.

5.5 m' Aluminium Rack The kit includes quality heavy duty aluminium racks to prevent rust and for reliable operation.

Sealed Casing to prevent insects, dust and rain from damaging the unit and ensuring long lasting operation.

Safety Anti-Crash Sensor Built-in over-current sensor protects the motor from damage in case the gate closes on an object accidentally.

? Semi / Automatic Operation two modes of operation can be selected: Automatic or Semi-automatic.

Auto-Close Operation Three preset built-in timers (10/25/50sec.) to choose from for time delay closure.

Two Over-Ride Keys for manual operation.

Product Information

Heavy Duty Motor
Digital controller
Back Up Battery
Pedestrian Entry Function
5.5m Rack upgradable to 7m
2 Remote controls



sliding gate automatic operation, press the remote and the gate will open fully or 1/2 way for pedestrians, Photoelectric sensors to prevent the gate from closing if something is in the way of the gate. The gate will slow down at the end of the opening and closing operation avoiding crashing sounds, once the gate is closed it can't be pushed open by intruders. The gate can be opened by Remote control (supplied), Keypad, Key switch, Intercom system with door or gate opening function and manual over ride

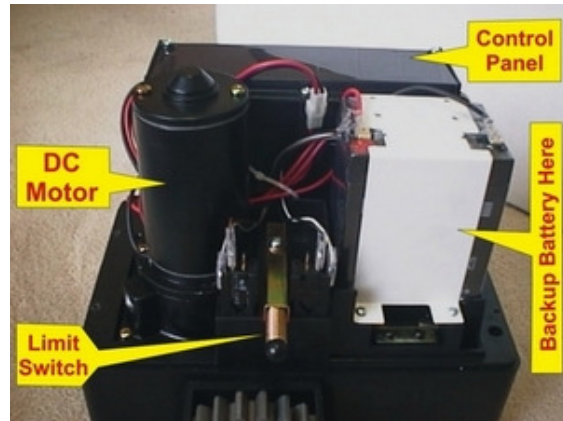

Heavy Duty DC Motor, mounting plate, Build In Controller Backup Battery, 12VDC 4Ah2, Remote Controls, 1 Pair Photoelectric sensors, Heavy Duty Rack for 5.5m gate, 2 Keys for manual over ride, AC Cable, Limit switch stopper to fit gate, Bolts and washers, Bushes.

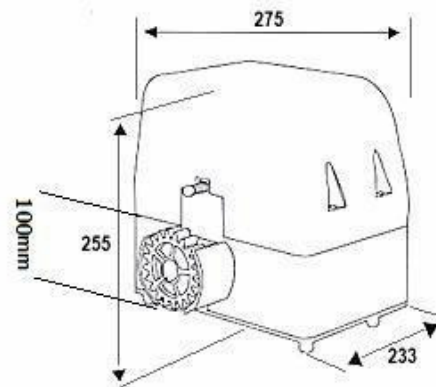

Specifications

Maximum door weight	400Kg
Speed	17cm/sec (no load)
Power supply	220/230 AC
Motor Type	12VDC
Working temperature	-20 to 55 deg C
Battery backup	12DC/4Ah

1300 633 623
ALL DAY FENCING